

SC1500

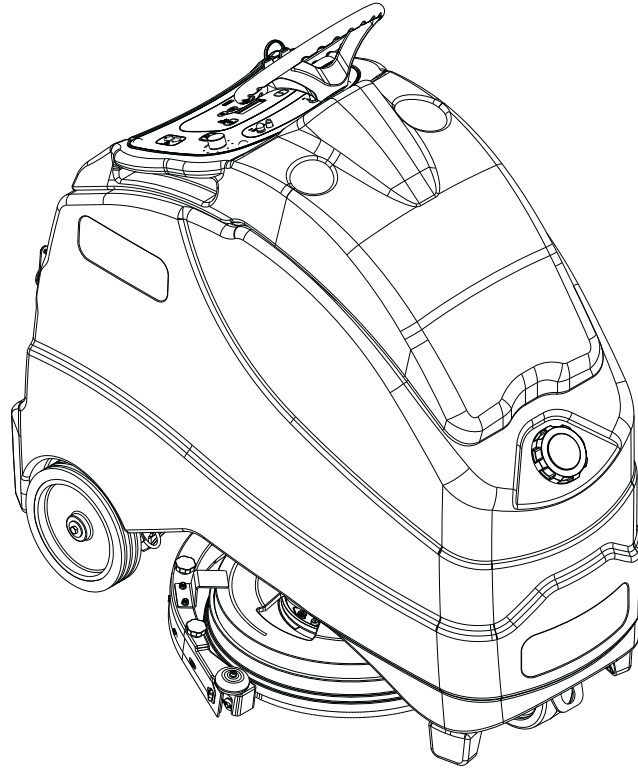

PARTS LIST

Advance MODELS 56104000, 56104001



Advance

11/12 revised 6/13 FORM NO. 56042591

GENERAL VIEW

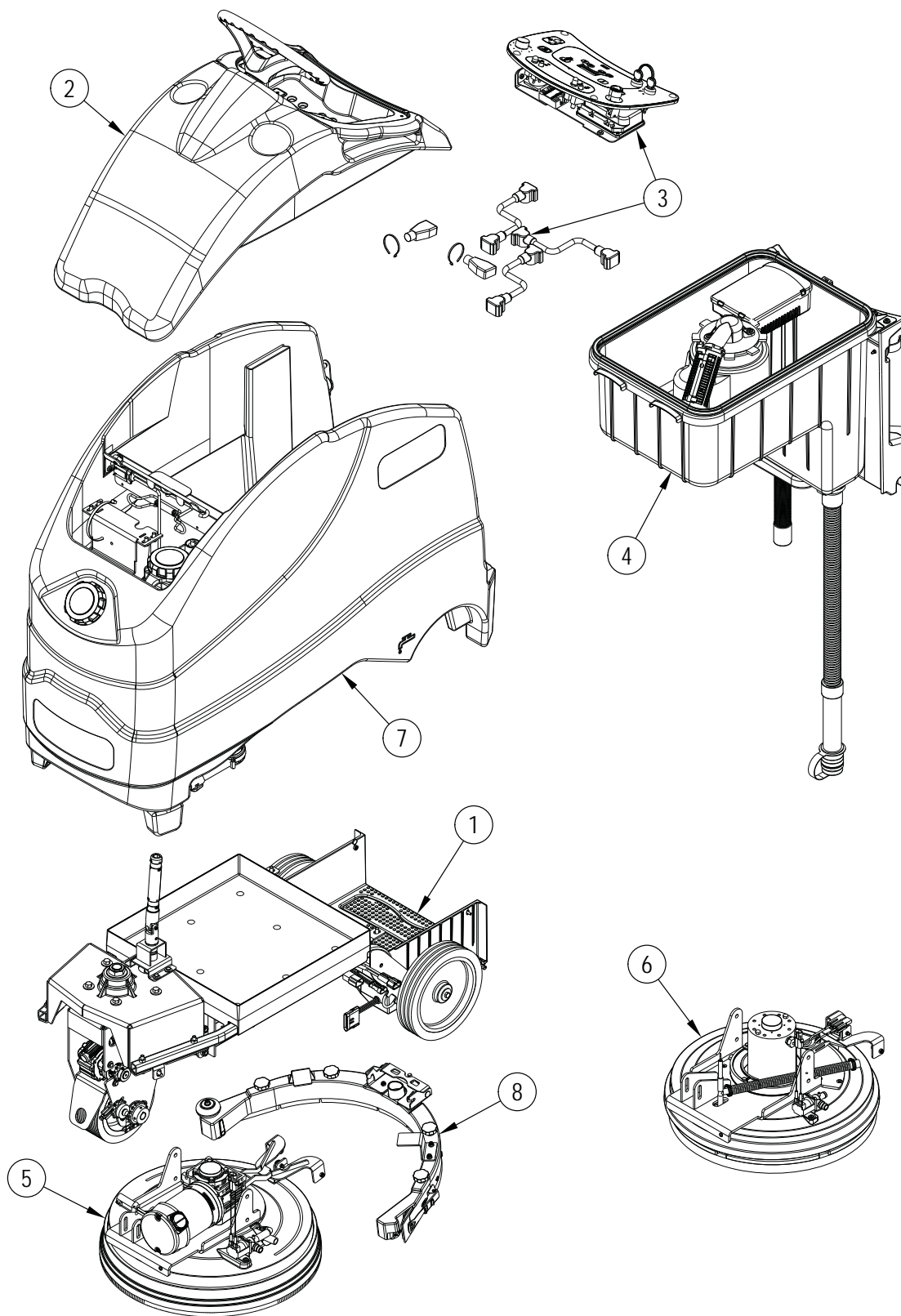

Item	Ref. No.	Qty	Description	Item	Ref. No.	Qty	Description
1		1	Chassis System	5		1	Scrub System-20D
2		1	Control System	6		1	Scrub System-REV
3		1	Electrical System	7		1	Solution System
4		1	Recovery System	8		1	Squeegee Assy

TABLE OF CONTENTS

DESCRIPTION	PAGE
Chassis System.....	2-3
Drive Wheel Assembly.....	4-5
Platform Assembly.....	6-7
Control System.....	8-9
Decal System.....	10-11
Electrical System.....	12-13
Recovery System.....	14-15
Scrub System-20D.....	16-17
Scrub System-REV.....	18-19
Solution System.....	20-21
Squeegee System.....	22-23
Ladder Diagram-1.....	24-25
Ladder Diagram-2.....	26-27
Optional Kits and Accessories.....	28
Recommended Spare Parts.....	29
Brush Selector Guide-Disk.....	30
Pad Selector Guide.....	31
Squeegee Blade Selector Guide.....	32

WHEN ORDERING PARTS

- * Use the part numbers from the "Ref. No." columns in this parts list. If the "Ref. No." column is blank; look under the "Kit" column to identify which kit contains the part in question, then use the kit callout, for example "K1", to find the "Ref. No." for that kit.
- * Specify the model and serial number of the machine.
- * Use the space below to record the model and serial number for future reference.

Kit	Item	Ref. No.	Qty	Description
K1	1		16	Washer Flat 3/16 Zinc Plat
K1	2		2	Screw-BHS-Brass-10-32x3/8-MS
K1	3		3	Washer EPDM 7/32 X 1/8
	4	805	1	Chain-Cover
	5	905	2	Caster Swivel 4 Gray Non MA
K1	6		2	Nut, Hex Nyl Loc 10-24
K1	7		3	Scr- Hex SS 1/4-20 X .75
K1	8		16	Scr, Hex Hd Loc 1/4-20 x .50
K1	9		3	Wsh, Flt SS .260 X 1.000 X .074
	10	56113012	1	Solution Tank
	11	56113034	2	Hinge Plate
K1		56113103	1	Kit-Hardware Solution Tank

Model _____ Serial No. _____

CHASSIS SYSTEM

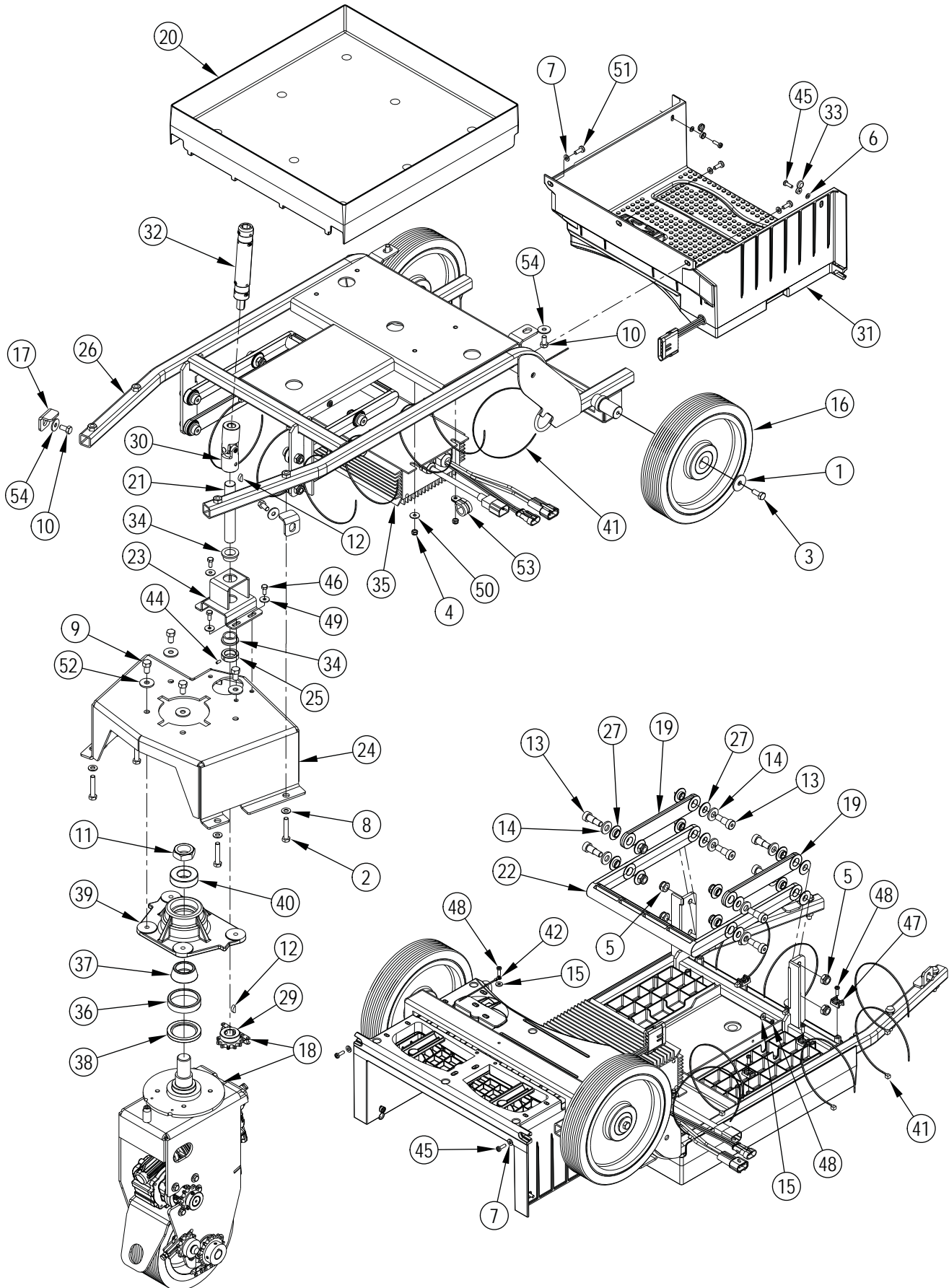

CHASSIS SYSTEM

Kit	Item	Ref. No.	Qty	Description	Kit	Item	Ref. No.	Qty	Description
K2,K4	1		2	Washer, Flat XI 9X32		29	56104269	1	Sprocket-11 Tooth
K4	2		4	Screw, Hex Hd M8x45-	K1	30		1	Universal Joint
K2,K4	3		2	Screw, Hex Thd To Hd M8x20 Ss		31#		1	Platform Assembly
K4	4		4	Nut, Hex Nyl Loc Thin M6		32	56104319	1	Tube-Steering Assembly
K4	5		8	Nut, Hex Nyl Loc Thin M10	K4	33		2	Screw Cap
K4	6		2	Washer, Flat 5,3X10		34#	56104267	2	Bearing Flange
K4	7#		5	Washer, Flat 6,4X12,5		35	56112544	1	Battery Charger 24V 25A (E2)
K4	8#		4	Washer, Flat 8.4X16X1.6	K3	36		1	Bearing Cup
K4	9		4	Scr-Hex Hd Loc 3/8-16x.62	K3	37		1	Bearing Cone
K4	10		4	Scr-Hex M8-1.25 X 16MM	K3	38		1	Seal,Shaft
K3	11		1	Nut, Hex Nyl Loc-Thin 1-14		39	56314032	1	Block, Bearing
K4	12		2	Key-Wdf 5MMX6.5MMX16MM	K3	40		1	Bearing Ball
K4	13		8	Scr-Soc Shd M12x16mmx M10-1.50	K4	41#		7	Tie, Cable
K4	14		8	Wsh-Flt 12mm	K4	42		1	Chain - Ball
K4	15		2	Wsh, Int Shprf #10	K4	43#	DELETED		
K2	16		2	Wheel	K4	44#		1	Screw Grub M5x10 Uni5929
	17	56104091	2	Mounting Tab	K4	45		4	Scr, Pan Phil M5x16
	18#		1	Drive Wheel Assembly	K4	46		3	Screw, Hex Thd To Hd M6x14
	19	56104094	2	Bar Linkage	K4	47		5	Flat Tie Holder
	20	56104105	1	Battery Tray	K4	48#		7	Thread Rolling Scr 5X16
	21	56104130	1	Steering Shaft	K4	49		3	Washer, Flat XI
	22	56104135	1	Link Bar	K4	50#		3	Washer, Flat XI Ss
	23	56104148	1	Steering Shaft Weldt	K4	51		3	Scr, Pan Phil M6x16
	24	56104151	1	Spindle Mount Weldment	K4	52		4	Washer, Flat XI 9.5X27X2.5
	25	56104157	1	Collar		53#	909 5516 000	1	Clamp 18
	26	56104170	1	Chassis Weldment	K4	54#		4	Washer Flat XI Uni-6593 8x24
K4	27		16	Bushing Link Arm					
	[28]	56104239	1	Harness-Drive Motor					
						K1	56104328	1	Kit-Universal Joint
						K2	56104331	1	Kit-Rear Wheel
						K3	56104332	1	Kit-Bearing Block
						K4	56104333	1	Kit-Chassis Hardware

= Revised or new since last update
 [] = Not Shown

DRIVE WHEEL ASSEMBLY

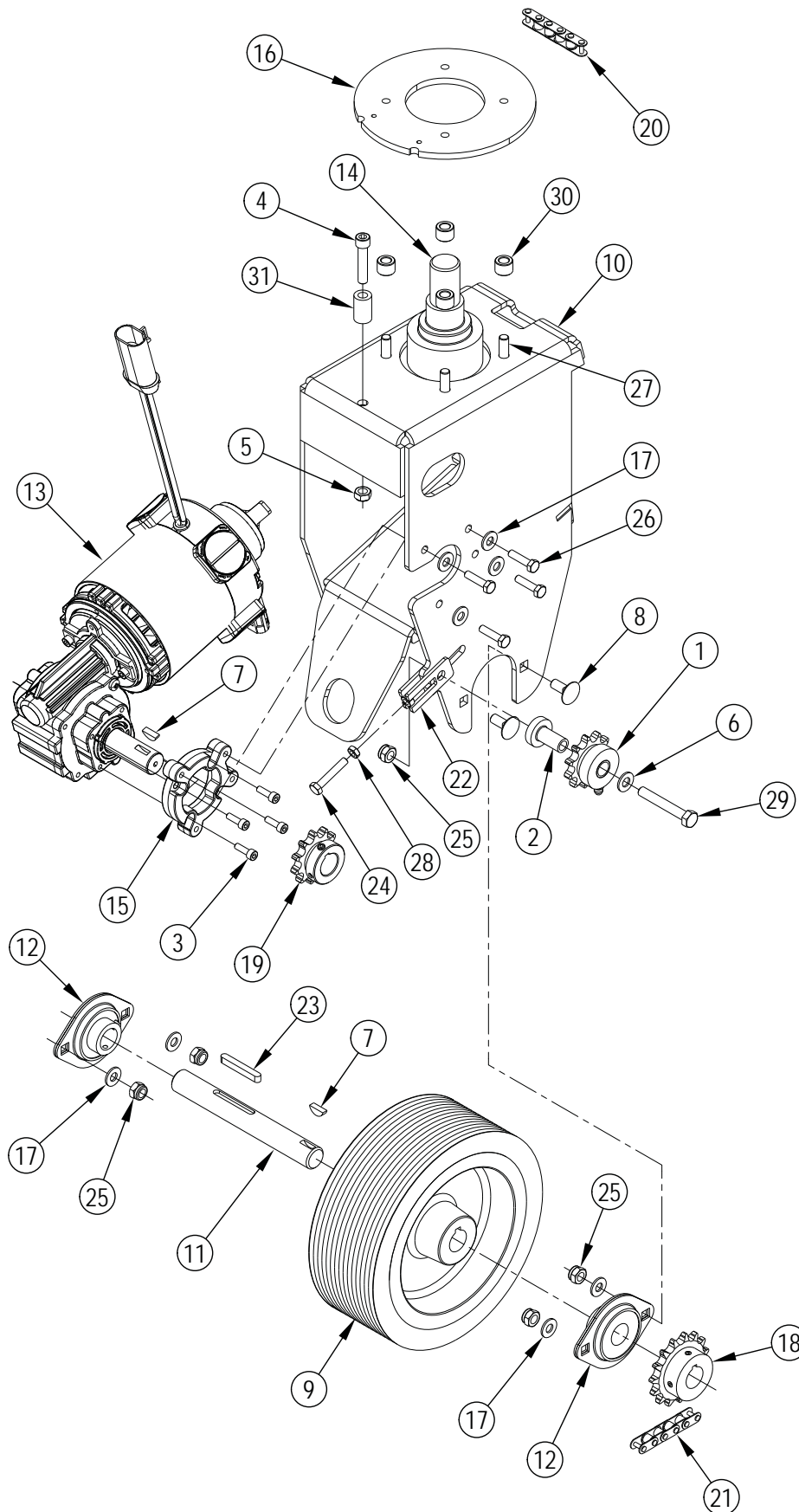

DRIVE WHEEL ASSEMBLY

Kit	Item	Ref. No.	Qty	Description
	#		1	Drive Wheel Assembly
K7	1		1	Sprocket Assy
K7,K8	2		1	Bushing, Flanged
K5,K8	3		4	Viti Tcei/Scr, Soc Hd
K8	4		1	Scr-Soc Hd 5/16-18 X 1.50
K8	5		1	Nut, Hex Nyl Loc-Thin 5/16-18
K7,K8	6		1	Wsh-Flt Sae Ss 5/16
K5,K6,K7	7		2	Key-Wdf 5mmx6.5mmx16mm
K6,K8,K9	8		4	Scr-Carriage Ss M8-1.25 X 20mm
K6	9		1	Drive Wheel
	10	56104058	1	Drive Wheel Frame Weldt
K6	11		1	Axle
K6,K9	12		2	Axle Bearing
K5	13		1	Drive Wheel Motor (M1)
	14	56104077	1	Spindle Weldt
K5	15		1	Spacer
	16	56104115	1	Steering Plate
K5,K6,K8, K9	17		8	Washer, Flat 8x17x1.6 Ss
K7	18		1	Sprocket-15 Tooth
K7	19		1	Sprocket-11 Tooth
	20	56104270	1	Chain-Roller
K7	21		1	Chain-Roller
K7	22		1	Weld't-Idler Adjust
K6	23		1	Key, 6mm Sq
K7,K8	24		1	Screw, Hex Thd To Hd M6x35 Ss
K6,K7,K8, K9	25		5	Nut, Hex Nyl Loc Thin M8 Ss
K5,K6,K8	26		4	Screw, Hex Thd To Hd M6x25 Ss
K8	27		4	Screw, Hex Thd To Hd M8x30 Ss
K7,K8	28#		1	Nut, Hex M6 SS
K7,K8	29		1	Screw, Hex Thd To Hd M8x55 Ss
K8	30		4	Spacer
K8	31		1	Spacer
	K5	56104336	1	Kit-Drive Wheel Motor
	K6	56104338	1	Kit-Wheel And Bearing
	K7	56104339	1	Kit-Sprocket And Chain
	K8	56104340	1	Kit-Drive Wheel Hardware
	K9	56104384	1	Kit-Front Wheel Bearings

= Revised or new since last update

PLATFORM ASSEMBLY

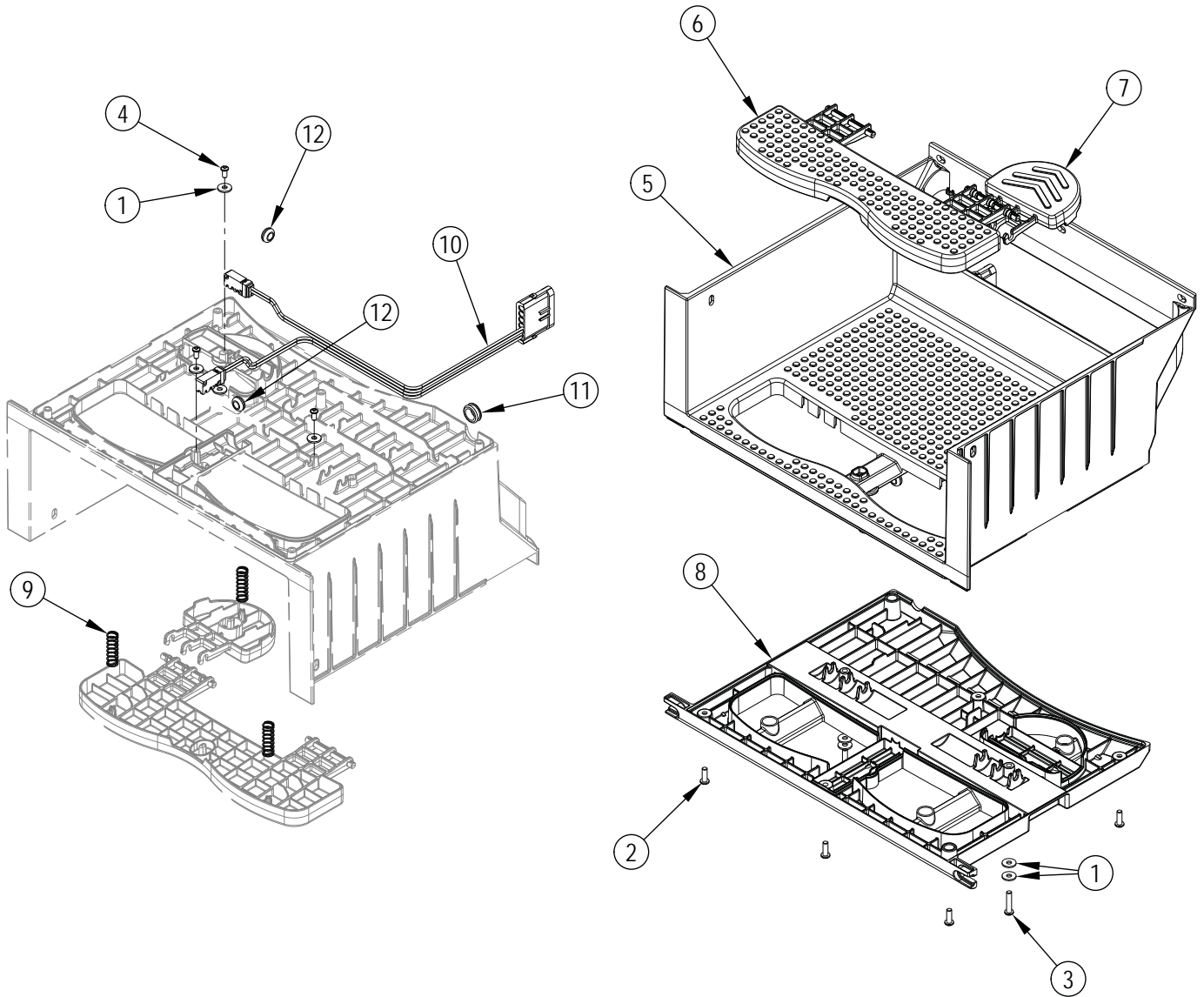

PLATFORM ASSEMBLY

Kit	Item	Ref. No.	Qty	Description
	#		1	Platform Assembly
K1	1#		8	Washer
K1	2#		6	Scr Pan Phil Plastit10-14x.62
K1	3#		2	Scr Pan Phil Plastite 10-14x1
K1	4		4	Scr-Pan Phil Plast M5x2.3x10mm
	5	56104052	1	Platform-Upper
	6	56104185	1	Pedal-Safety
	7	56104186	1	Foot Pedal
	8	56104187	1	Platform-Bottom
	9	56104277	3	Compression Spring
	10	56104406	1	Switch Harness (S2, S5)
	11	56158690	1	Grommet
	12	56331006	2	Grommet
K1	56104417		1	Kit-Platform Hardware

= Revised or new since last update

CONTROL SYSTEM

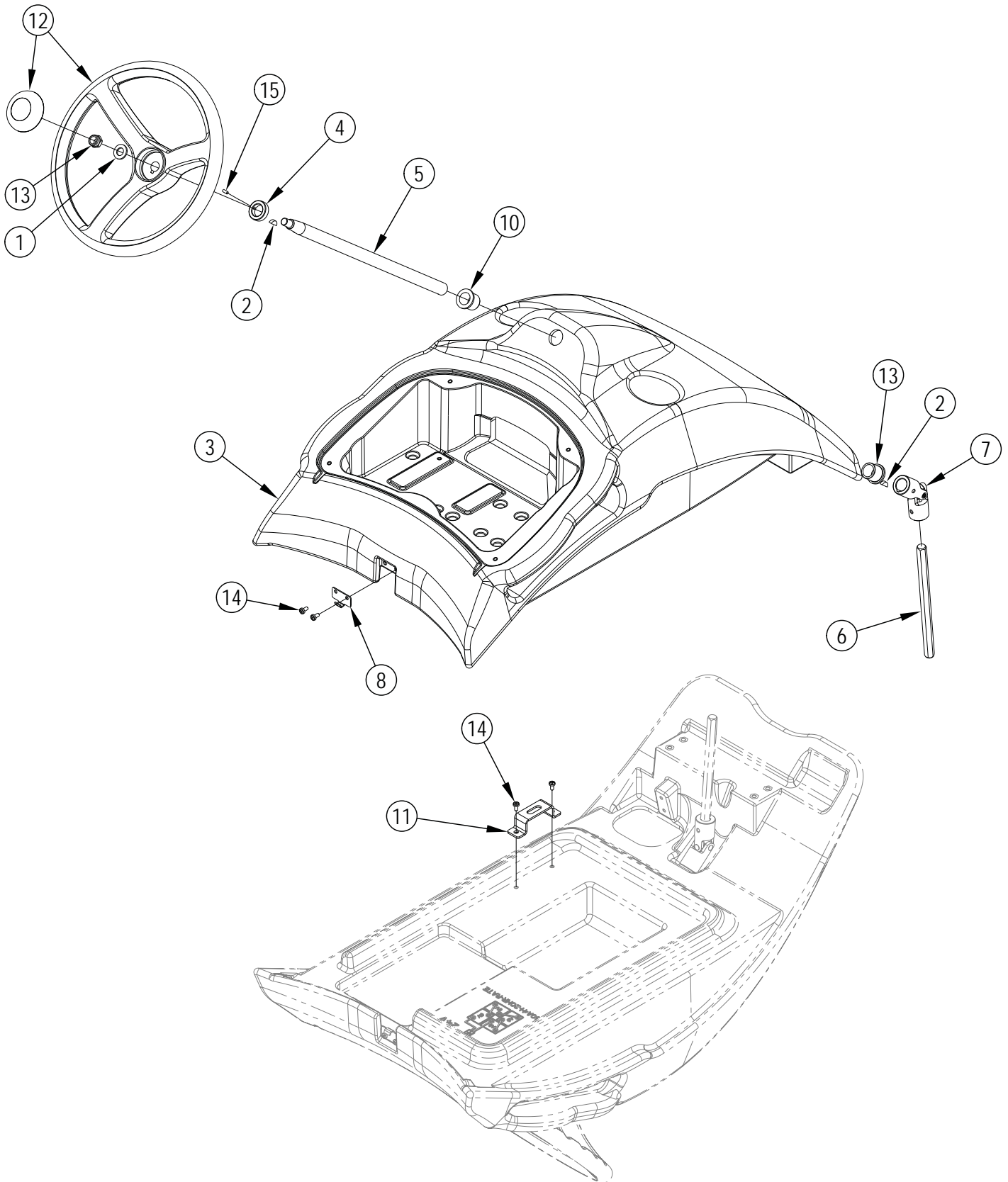

CONTROL SYSTEM

Kit	Item	Ref. No.	Qty	Description
K3	1		1	Washer, Flat 13X24
K3	2		2	Key-Wdf 5mmX6.5mmX16mm
	3	56104053	1	Control Panel
K3	4		1	Collar
	5	56104196	1	Shaft Steering
	6	56104265	1	Shaft Hex
K1	7		1	Universal Joint
K2	8		1	Hook Latch
K2,K3	9#	DELETED		
K3	10		2	Bearing-Flange
	11	56104410	1	Bracket-Prop Rod
	12	56601060	1	Steering Wheel
K3	13		1	Nut, Hex Nyl Loc Thin M12
K2,K3	14		4	Scr, Pan Phil M5x10 Ss
K3	15#		1	Screw Grub M5x10 Uni5929
	K1	56104328	1	Kit-Universal Joint
	K2	56104352	1	Kit-Draw Latch
	K3	56104365	1	Kit-Control Hardware

= Revised or new since last update

DECAL SYSTEM

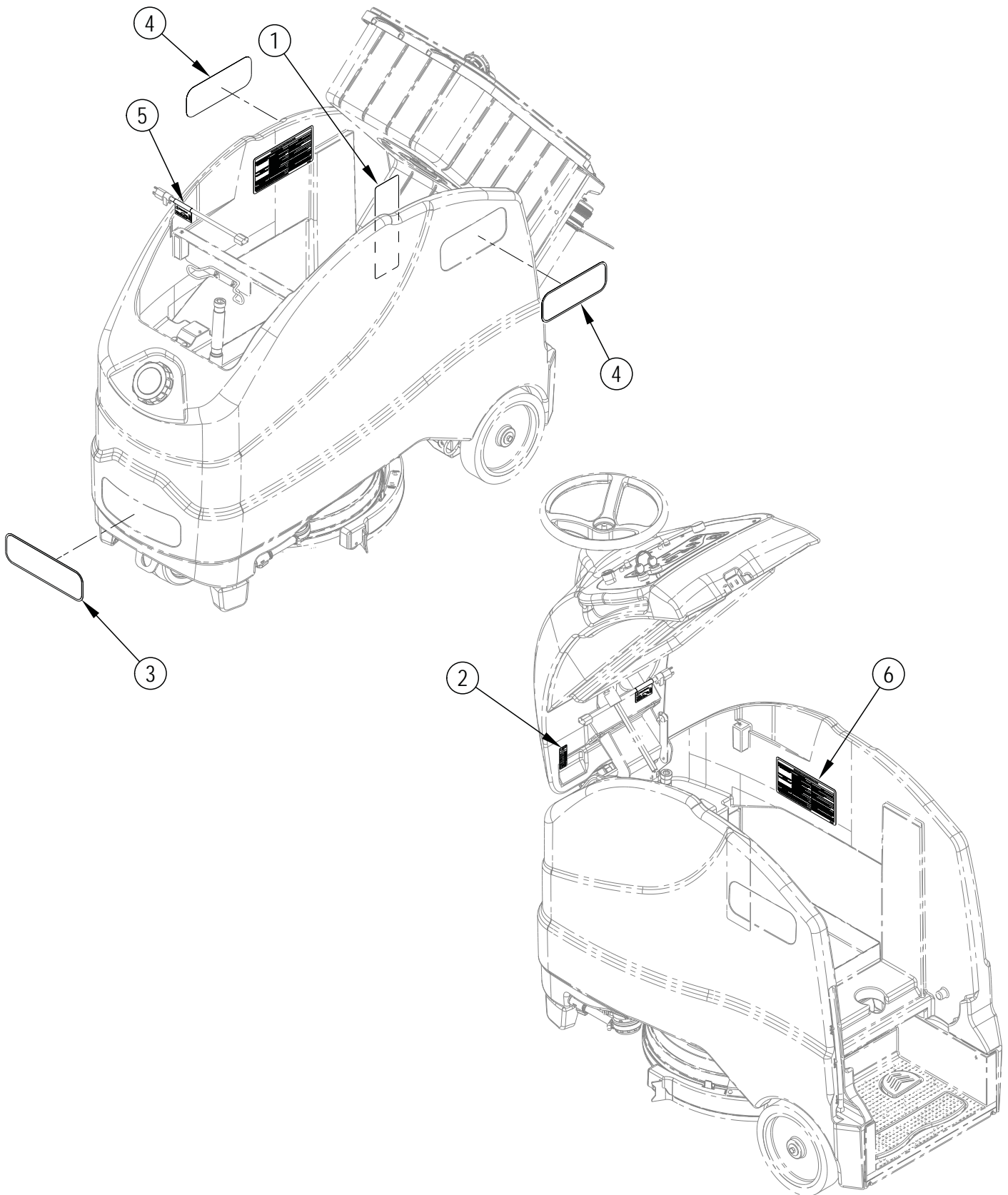

DECAL SYSTEM

Kit	Item	Ref. No.	Qty	Description
K1,K2	1		1	Decal, Caution
K1,K2	2		1	Decal-Chemical Ratio
K1,K2	3		1	Decal-Advance
K1	4		2	Decal-Sc1500
K2			2	Decal-Sc1500 Rev
K1,K2	5		1	Decal-Charger Cord
K1,K2	6		1	Decal-Error Codes
K1,K2	7	DELETED		
	K1	56104334	1	Kit-Decal Sc1500
	K2	56104348	1	Kit-Decal Sc1500 Rev

= Revised or new since last update

ELECTRICAL SYSTEM

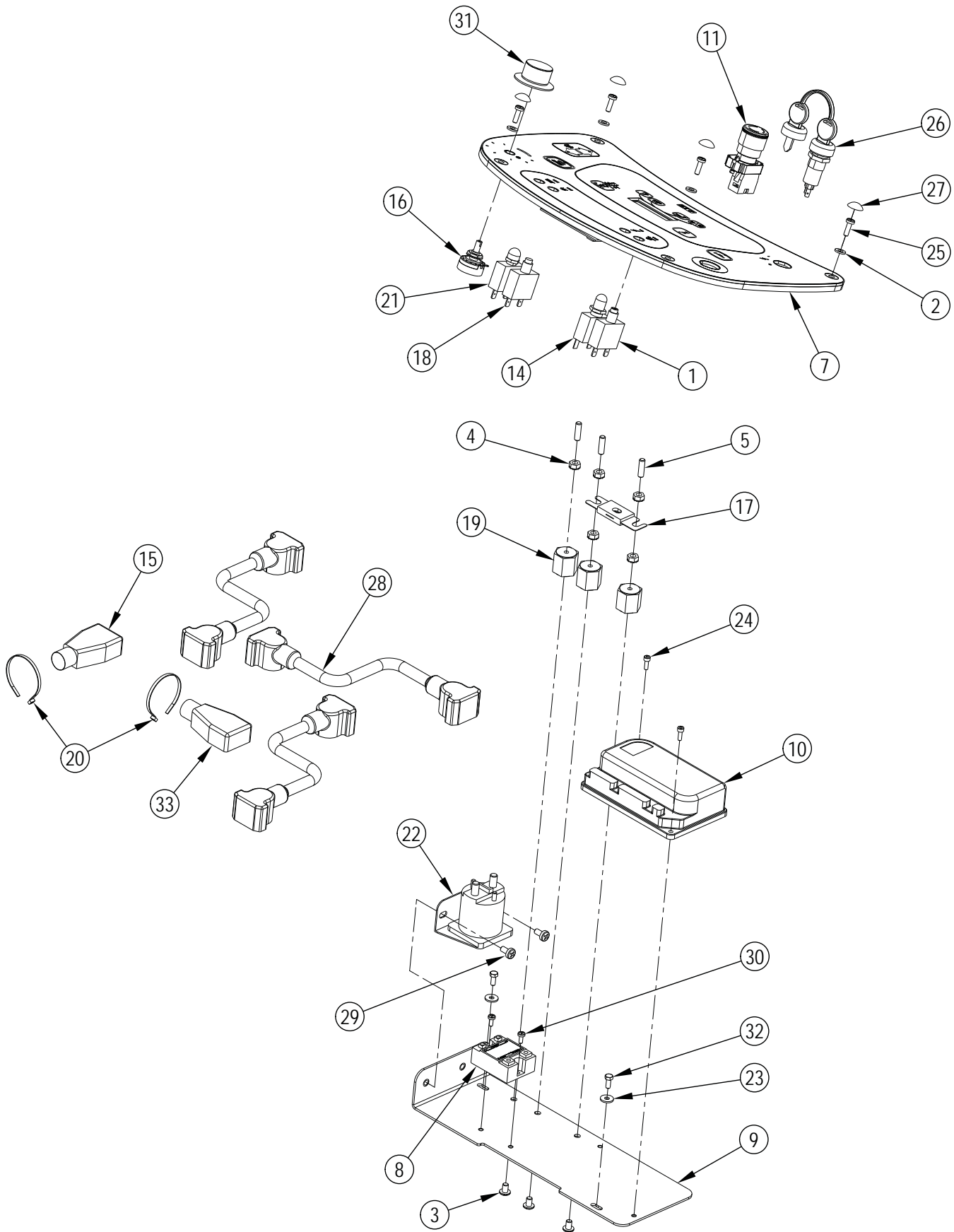

ELECTRICAL SYSTEM

Kit	Item	Ref. No.	Qty	Description
	1#	56104423	1	Circuit Breaker 50 Amp (CB1)
K1	2		4	Washer, Flat 6,4x12,5
K1	3		3	Scr-Pan Phil 1/4-20 X .38
K1	4		5	Nut, Hex W/ Shprf 1/4-20
K1	5		3	Stud
	[6]	56104083	1	Harness-Main
K2	7		1	Interface Panel Assembly (A1)
K3	*		1	Kit-Interface Panel
	8	56104176	1	Solid State Relay (K1)
	9	56104193	1	Electrical Panel
	10	56104243	1	Speed Controller (E1)
	11	56104247	1	Disconnect-Emergency
	[12]	56104282	1	Cable-Power Red
	[13]	56104283	1	Cable-Power Black
	14	56315255	1	Circuit Breaker, 5 Amp (CB2)
	15#	2-00-05171	1	Bat Terminal Cover Red
	16	56396197	1	Potentiometer, 100k (R1)
	17	56412089	1	Fuse, 150 Amp (F1)
	18	56413822	1	Circuit Breaker, 20 Amp (CB3)
	19	56469858	3	Electrical Mount
	20	56478246	2	Tie, Cable
	21	56509623	1	Circuit Breaker-25 Amp (CB4)
	22	56601183	1	Contacto 24v, 100 Amp (K2)
K1	23		2	Washer, Flat XI 5,5x15x1,2 Ss
K1	24		2	Viti Tcei/Scr, Soc Hd
K1	25		4	Scr, Pan Phil M5x16
	26	1462888000	1	Switch, Key With Water Proof Cup (S1)
K1	27		4	Cover For Screw Tcb 4.8mm
	28	40172A	3	Cable,Battery
K1	29		2	Scr, Pan Phil M6x12
K1	30		2	Scr, Pan Phil M4x10
	31	50962A	1	Knob, Speed Control
K1	32		2	Screw, Hex Thd To Hd M5x12
	33#	2-00-05173	1	Bat Terminal Cover Blk
	K1	56104341	1	Kit-Electrical Hardware
	K2	56104371	1	Kit-Control Board
	K3	56104372	1	Kit-Interface Panel

= Revised or new since last update

[] = Not Shown

* = Optional, Not Included

RECOVERY SYSTEM

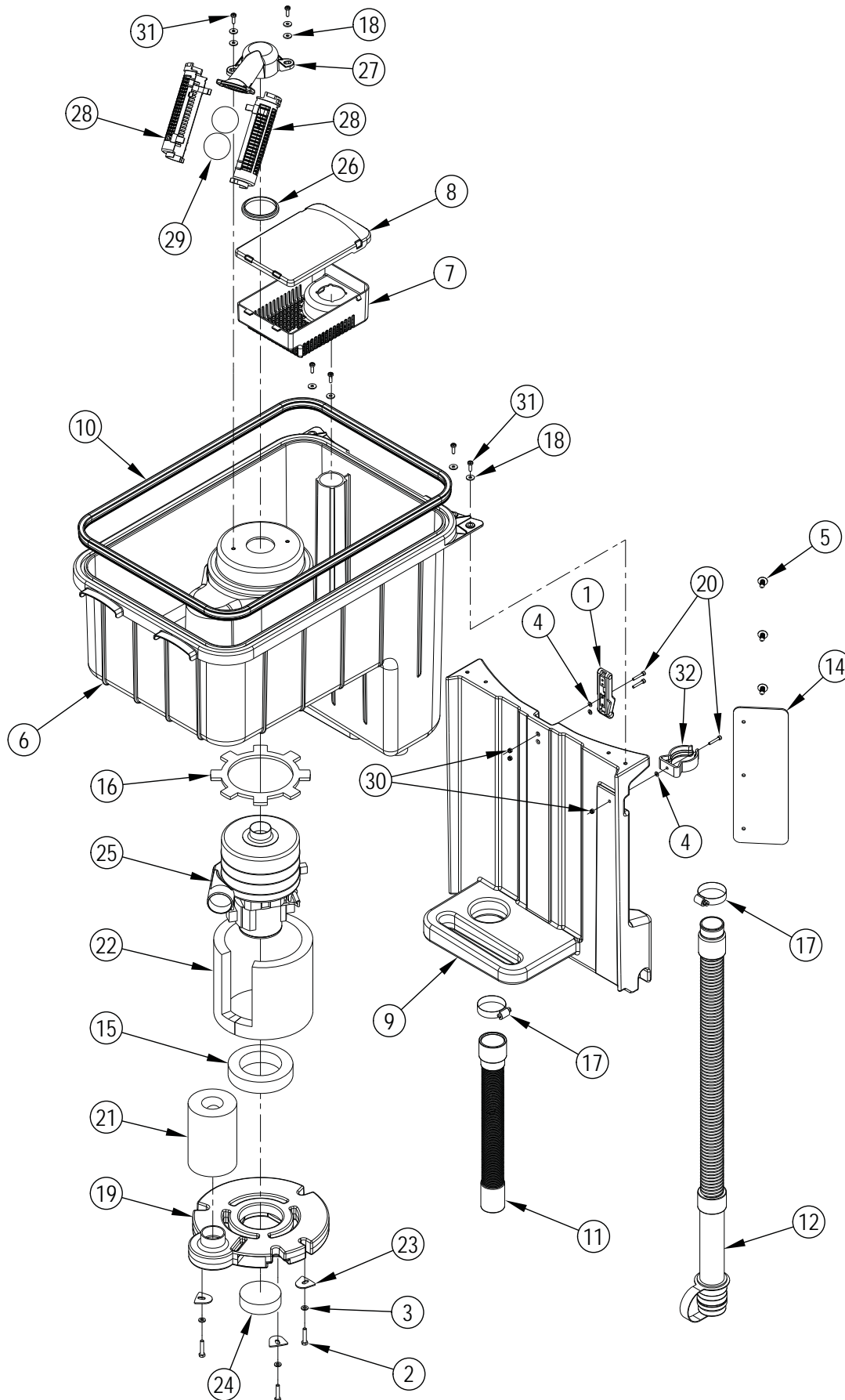

RECOVERY SYSTEM

Kit	Item	Ref. No.	Qty	Description
K1	1		1	Latch, Draw
K7	2		3	Screw, Hex Thd To Hd M6x30
K7	3		3	Washer, Flat 6,4x12,5 S.S.
K1,K5,K7	4		3	Washer, Flat 4,3x9
K7	5		3	Rivet, Nylon Tree Push-In (.25)
	6	56104051	1	Recovery Tank
K4	7		1	Debris Cage
K4	8		1	Debris Tray Cover
	9	56104158	1	Back Panel
	10	56104164	1	Gasket-Recovery Tank
	11	56104258	1	Vac Hose Assy
	12	56104285	1	Drain Hose
	[13]	56104306	1	Jumper Harness
	14	56104320	1	Splash Guard
K8	15		1	Vacuum Motor Support Gasket
K6	16		1	Gasket, Vacuum Motor
	17#	145 0543 000	2	Hose Clamp 14/32-52
K2,K7	18		8	Washer, Flat XI 5,5x15x1,2 Ss
	19	909 6051 000	1	Cover, Vac
K1,K5,K7	20		3	Viti Tcei/Scr, Soc Hd
K8	21		1	Insulation Tube
K8	22		1	Panel, Acoustic Insulation
K7	23		3	Plate Cover
	24	909 6672 000	1	Filter
K6	25		1	Vacuum Motor 3 Stage 24v (M4)
K2	26		1	Gasket Float Support
K2	27		1	Support Float Support System
K2	28		2	Float Cage
K2	29		2	Ball Float
K1,K5,K7	30		3	Nut, Hex Nyl Loc Thin M4 Ss
K2,K7	31		6	Scr,Pan Phil M5x16 Ss
K5	32		1	Clamp, Hose D.50
	K1	56104352	1	Kit-Draw Latch
	K2	56104359	1	Kit-Float Cage
	K4	56104360	1	Kit-Debris Cage
	K5	56104362	1	Kit-Hose Clamp
	K6	56104363	1	Kit-Vacuum Motor
	K7	56104364	1	Kit-Recovery Hardware
	K8	56104383	1	Kit-Vacuum Motor Insulation

= Revised or new since last update

[] = Not Shown

SCRUB SYSTEM-20D

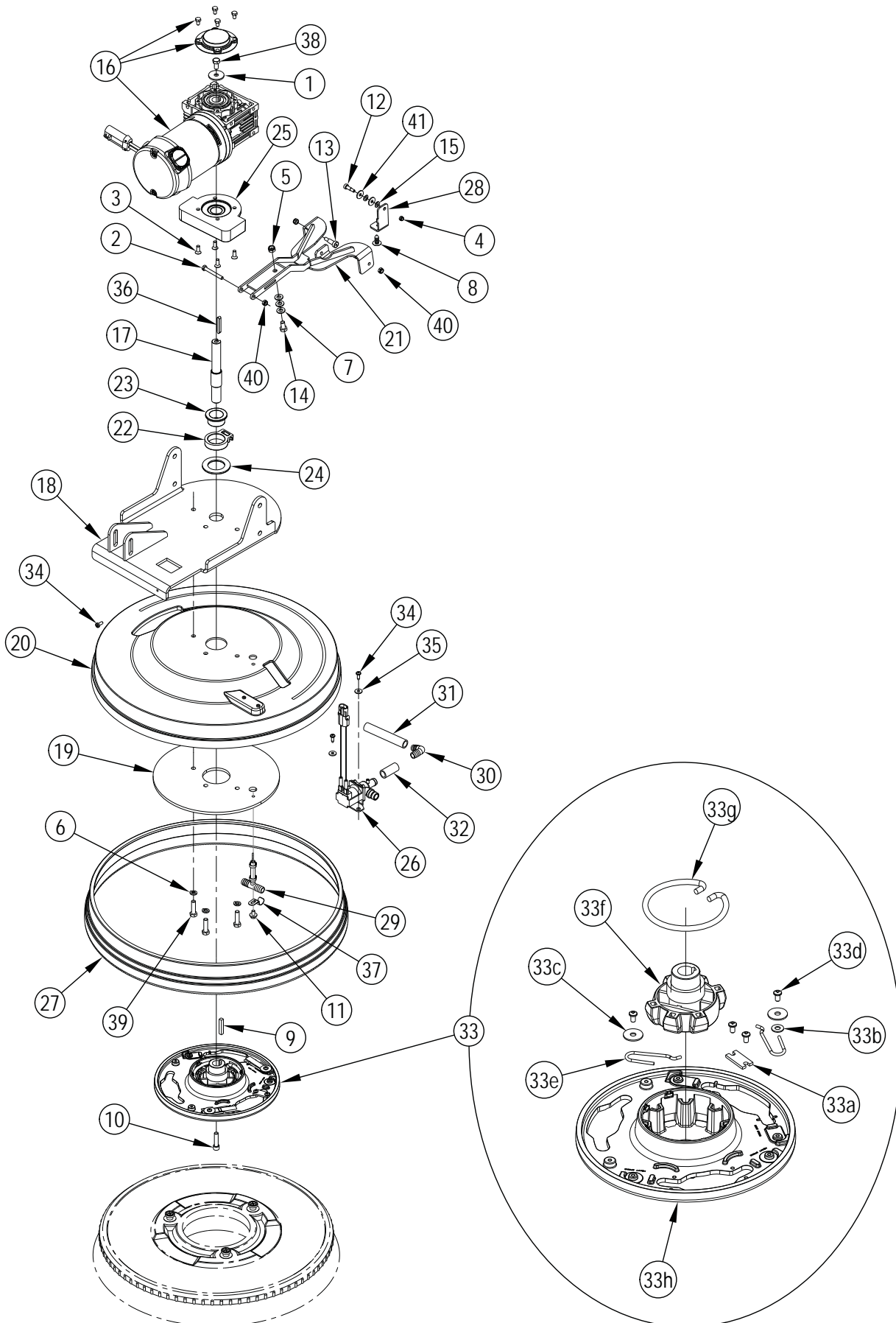

SCRUB SYSTEM-20D

Kit	Item	Ref. No.	Qty	Description	Kit	Item	Ref. No.	Qty	Description
K2	1		1	Washer, Flat XI 9X32		33	56601733	1	Brush Plate Assy Rt
K2	2		1	Screw, Hex Thd To Hd M6x50		33a	56366455	1	Plate, Stop
K2	3		4	Screw, Flat Socket Head	K2	33b		1	Wsh, Flt Std #10
K2	4		1	Nut, Hex Nyl Loc Thin M5	K2	33c		2	Wsh, Flt .266 X .906 X .060
K2	5		1	Nut, Hex Nyl Loc Thin M8	K2	33d		4	Scr, Pan Phil Plastiite 10-14 X .38
K2	6		3	Washer, Split Lock D.8	33e	56109653		2	Spring Retainer
K2	7#		3	Washer, Flat 8.4X16X1.6	33f	56112521		1	Gimbal-Collar Assembly
K2	8		1	Rivet, Nylon Tree Push-In (.25)	33g	56601056		1	Spring, Brush Holder
K2	9		1	Key, Square .25 X 1.44	33h	56601118		1	Brush Plate
K2	10		1	Scr-Soc Hd 5/16-18 X 1.25 Zinc	K2	34#		2	Scr, Pan Hd Thd Form
K2	11		1	Scr-Hex Thd Form M6 X 10mm	K2	35		2	Washer, Flat XI 5,5X15X1,2 Ss
K2	12		1	Scr-Soc Shd M6x12mm X M5-0.8	K2	36		1	Key
K2	13		2	Scr-Soc Shd M8x16mm X M6-1.00	37	909 5483 000		1	Hose Holder
K2	14		1	Scr-Hex Plastic M8-1.25 X 16MM	K2	38		1	Screw, Hex Thd To Hd M8x16 Loctite
K2	15		2	Wsh, Bowed .266x.500x.060	K2	39		3	Screw, Hex Thd To Hd M8x30 Ss
	16	56104071	1	Disc Brush Motor (A-F) (M5)	K2	40		3	Nut, Hex Nyl Loc Thin M6 Ss
	17	56104095	1	Shaft Disc Brush Motor	K2	41		2	Washer, Flat XI Ss
	18	56104117	1	Deck Lift Plate Weldment	K2	42#		1	Screw Cyl Hd M5x12
	19	56104120	1	Lower Deck Plate					
	20	56104121	1	Brush Housing					
	21	56104126	1	Squeegee Link Weldment	Kit	Item	Ref. No.	Qty	Description
K1	22		1	Squeegee Pivot Block	A	56104297		1	Motovario Gearbox 15/1
K1	23		1	Bearing Flange	B	56104298		1	Motor
K1	24		1	Squeegee Pivot Washer	C	56104300		1	Brush Housing Assembly
	25	56104137	1	Spacer Motor	D	56601588		1	Cover And Screws
	26	56104169	1	Solenoid Valve Assy (L1)	E	56601508		1	Plastic Cover
	27	56104240	1	Skirt Brush	F	56601534		1	Carbon Brushes (2)
	28	56104241	1	Double Scrub Brkt					
	29	56314983	1	Tee Assembly					
	30	56386183	1	Barbed Elbow 90					
	31	56397209	1	Hose, Pvc, Clear .50 X 4.00					
	32	56397217	1	Hose, Pvc Clear					
K1	56104344		1	Kit-Squeegee Pivot					
K2	56104346		1	Kit-Disc Deck Hardware					

= Revised or new since last update

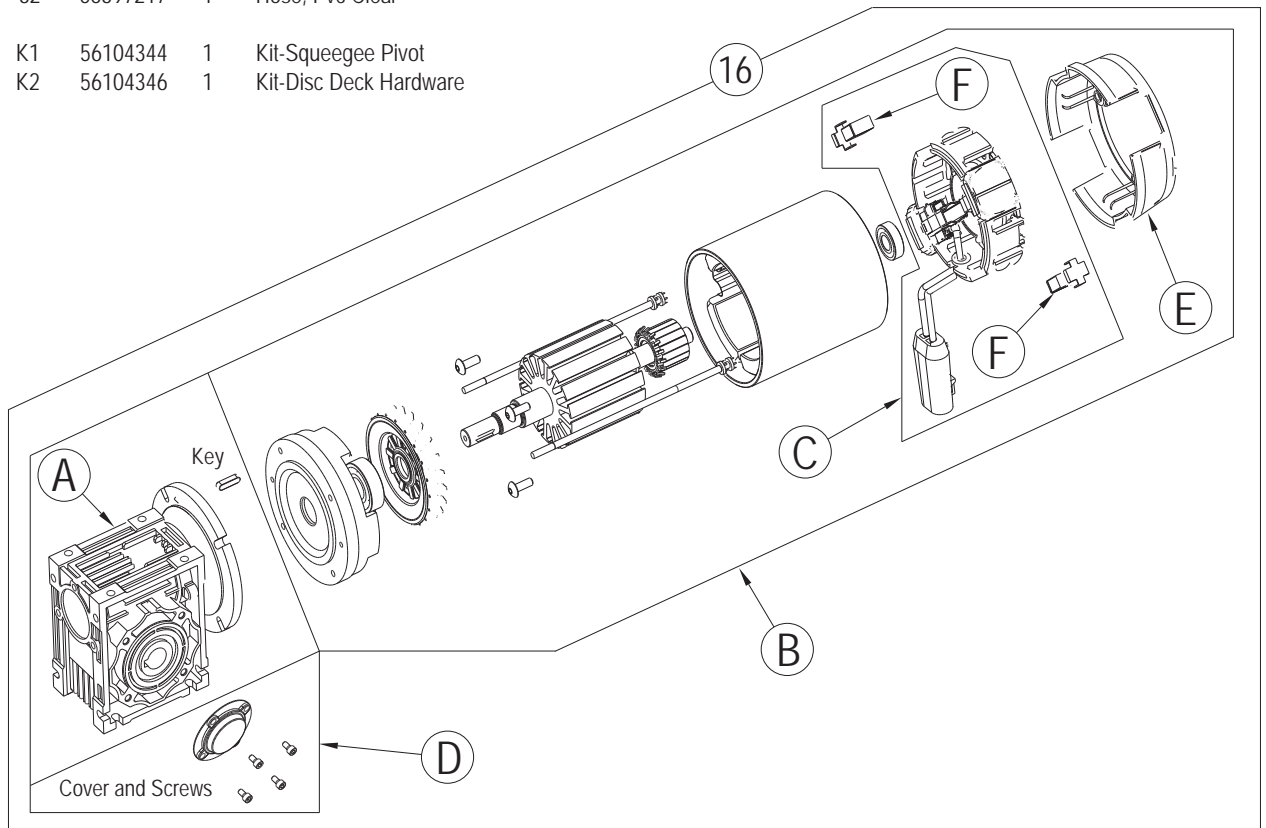

SCRUB SYSTEM-REV

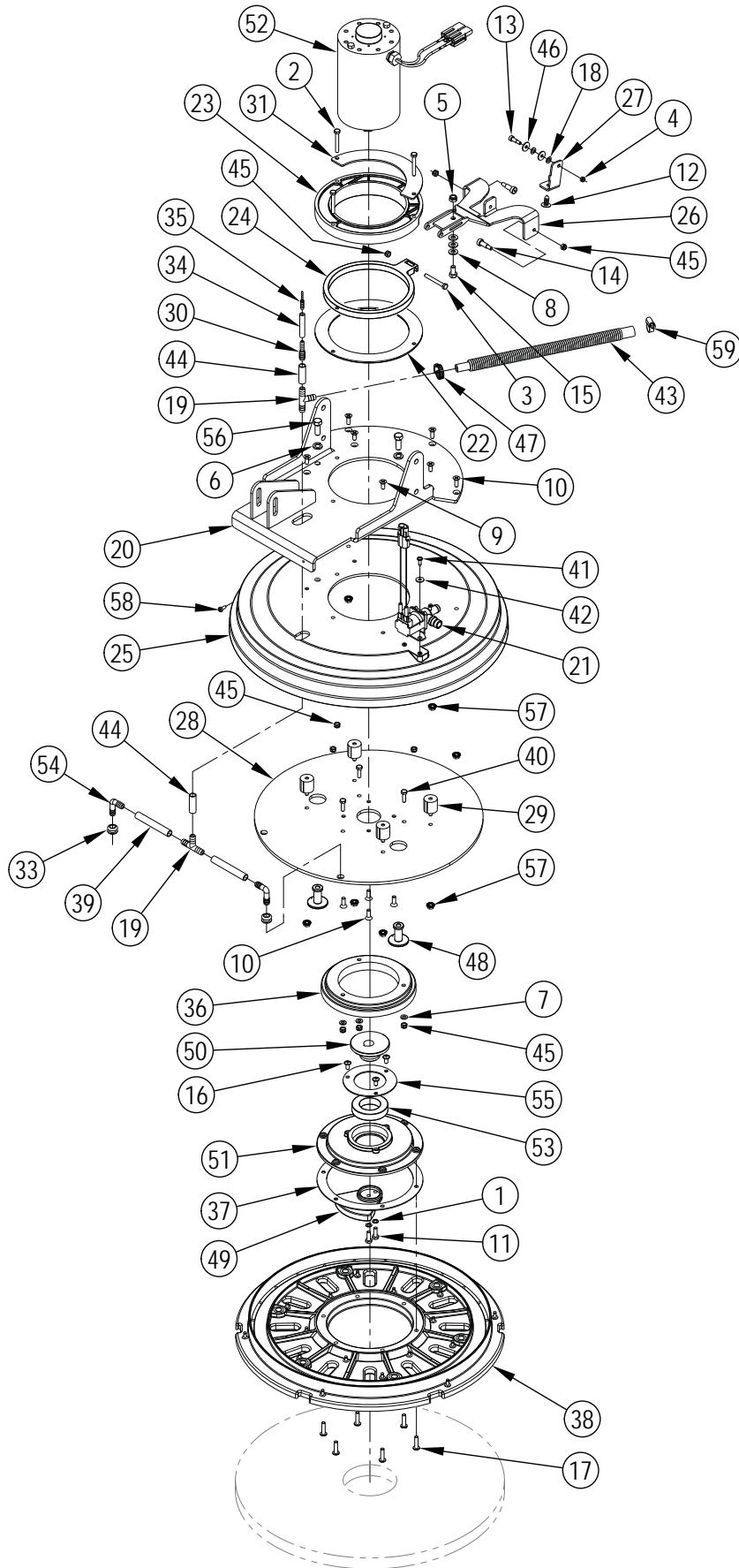

SCRUB SYSTEM-REV

Kit	Item	Ref. No.	Qty	Description	Kit	Item	Ref. No.	Qty	Description
K1	1		2	Helical Spring Lock Washer 1/4	K4	33		2	Grommet
K1,K2	2		3	Screw, Hex Thd To Hd M6x45	K4	34		1	Hose,Chem Resistant, 2"
K1	3		1	Screw, Hex Thd To Hd M6x50	K4	35		1	Reducer,Barb
K1	4		1	Nut, Hex Nyl Loc Thin M5		36	56390011	1	Shield Splash
K1	5		1	Nut, Hex Nyl Loc Thin M8		37	56390038	1	Gasket Driver
K1	6		2	Washer, Split Lock D.10		38	56390044	1	Pad Driver Assy
K1	7		3	Washer, Flat 6,4x12,5 S.S.	K4	39		2	Clear Vinyl Hose
K1	8#		3	Washer, Flat 8.4x16x1.6	K1	40		3	Screw, Hex Thd To Hd M6x20 Ss
K1,K3	9		4	Scr-Fit Phil 1/4-20 X .62	K1	41#		2	Scr, Pan Hd Thd Form
K1	10		7	Scr-Fit Phil Loc 1/4-20 X .75	K1	42		2	Washer, Flat XI 5,5x15x1,2 Ss
K1	11		2	Scr-Hex Hd Loc 1/4-20x.75	K4	43		1	Hose Solution Flex
K1	12		1	Rivet, Nylon Tree Push-In (.25)	K4	44		2	Hose Clear Vinyl 3/8 Id X 11/2
K1	13		1	Scr-Soc Shd M6x12mm X M5-0.8	K1,K2	45		9	Nut, Hex Nyl Loc Thin M6 Ss
K1	14		2	Scr-Soc Shd M8x16mm X M6-1.00	K1	46		2	Washer, Flat XI Ss
K1	15		1	Scr-Hex Plastic M8-1.25 X 16mm	K4	47#		1	Clamp, Hose
K1	16		3	Scr-Pan Phil Loc Ss 1/4-20 X .50		48	56381532	2	Stud Stabilizer Short
K1	17		6	Scr-Pan Phil Loc Ss 1/4-20 X 1.00		49	56390002	1	Weight Counter
K1	18		2	Wsh, Bowed .266x.500x.060		50	56390021	1	Eccentric
K4	19		2	Tee, Hose		51	56390027	1	Driver Motor
	20	56104138	1	Rev Lift Plate Weldment		52	56390072	1	Motor 24vdc (M5)
	21	56104169	1	Solenoid Valve Assy (L1)		[]	56412287	1	Carbon Brush Set Of 2 (for 56390072)
K2	22		1	Washer Squeegee		53	50736A	1	Bearing
K2	23		1	Bushing Squeegee	K4	54		2	Hosebarb, 90 Degree
	24	56104201	1	Plate Pivot		55	61775A	1	Retainer, Bearing
	25	56104202	1	Housing Rev	K1	56		2	Screw 3/8-24 X 1 Hex Head
	26	56104203	1	Squeegee Link Weldment	K1,K3	57		7	Nut, Serrated Flange
	27	56104241	1	Double Scrub Brkt	K1	58#		1	Screw Cyl Hd M5x12
	28	56104244	1	Plate Motor	K4	59#		1	Pipe Clamp--M10xm16
K3	29		4	Isolator-40 Duro 1/4-20					
K4	30		1	Reducer Barb	K1	56104367		1	Kit-Rev Deck Hardware
K2	31		1	Brkt-Squeegee Bushing	K2	56104368		1	Kit-Rev Squeegee Pivot
[32]	56114200		1	Connector-Adaptor	K3	56104369		1	Kit-Isolator
					K4	56104370		1	Kit-Rev Solution Hose

= Revised or new since last update

[] = Not Shown

SOLUTION SYSTEM

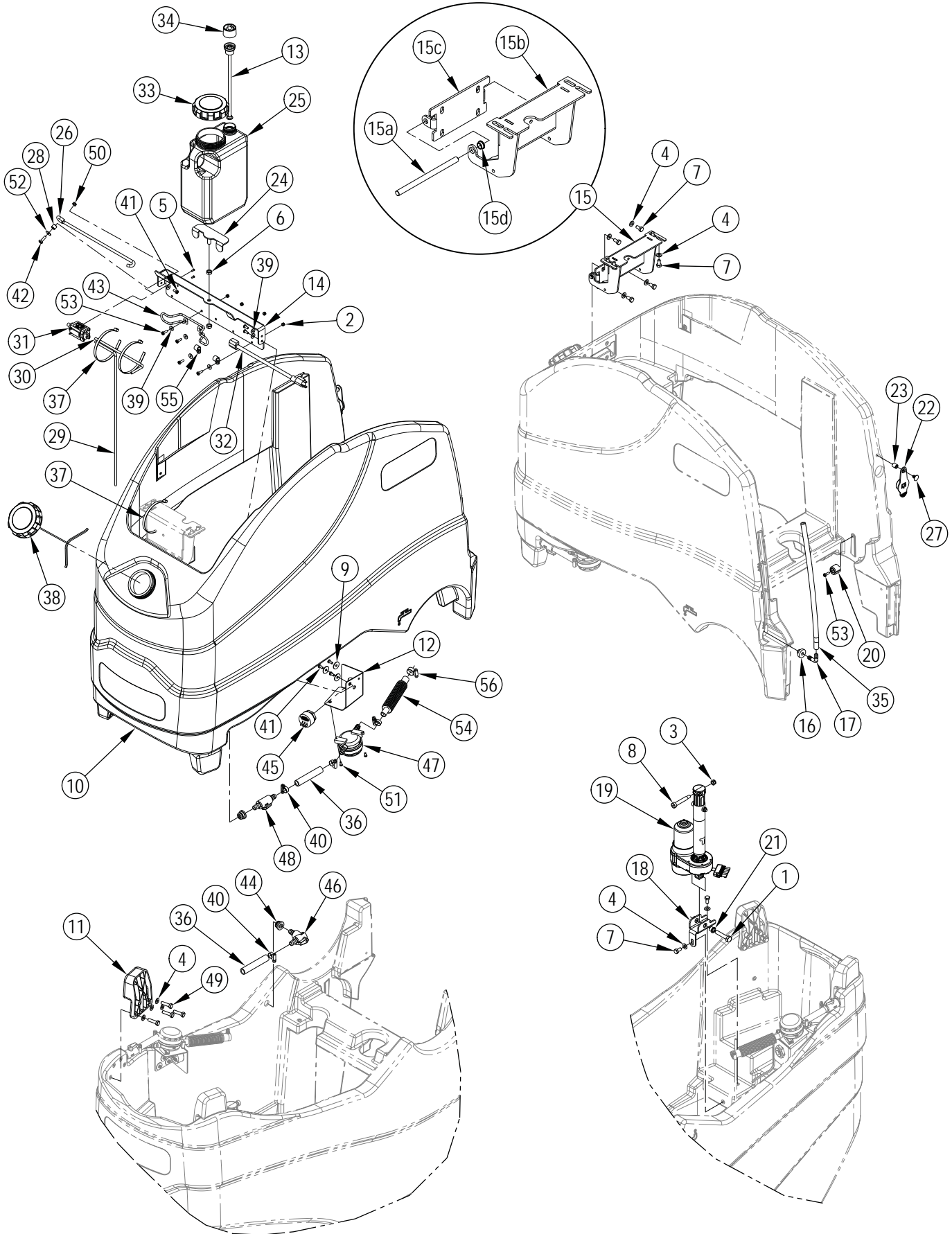

SOLUTION SYSTEM

Kit	Item	Ref. No.	Qty	Description	Kit	Item	Ref. No.	Qty	Description
K5,K7	1		1	Screw, Hex Thd To Hd M10x50		31	56315241	1	Pump, Chemical (M2)
K7	2#		4	Nut, Hex Nyl Loc Thin M5		32	56315270	1	Charger Cord, Us
K5,K7	3		1	Nut, Hex Nyl Loc Thin M8		33	56315517	1	Cap, Raw
K6,K7	4		18	Washer, Flat 8.4x16x1.6		34	56315523	1	Cap, Dry Break, 1/8 Barb, 90\$
K7	5		2	Scr, Pan Phil Thd Form 6-32 X .31		35	56393382	1	Hose-Pvc Clear
K7	6		2	Nut, Hex Nyl Loc-Thin Ss 3/8-16	K1,K2	36		2	Hose, Spiral .500
K7	7		10	Scr-Hex M8-1.25 X 16mm		37#	56477613	3	Tie, Cable
K5,K7	8		1	Scr-Soc Shd M10x50mm X M8-1.25		38	56601599	1	Cap - Raw With Tether
K7	9		3	Wsh, Flt .266 X .906 X .060	K7	39#		7	Washer, Flat XI 5,5x15x1,2 Ss
	10	56104050	1	Solution Tank	K1,K2	40#		4	Clamp, Hose 8/9-16clamp, Hose B32hs
K6	11		2	Tip Pad	K7	41		6	Scr, Pan Phil M5x12 Ss
	12	56104165	1	Filter Bracket	K7	42		1	Scr, Pan Phil M6x20 Ss
	13	56104189	1	Insert-Dry Break		43	909 5149 000	1	Cable Support
	14	56104194	1	Support Brkt	K1,K2	44		2	Gasket
	15#		1	Hinge Assembly		45	909 6126 000	1	Buzzer 5-32v (H1)
	15a	56104206	1	Hinge Pin	K1	46		1	Ball Valve 90°
	15b	56104207	1	Hinge Weldment	K3	47		1	Filter, Water
	15c	56104208	1	Hinge Bracket	K2	48		1	Ball Valve
	15d	56104249	2	Bearing Flange	K6,K7	49		8	Screw, Hex Thd To Hd M8x30 Ss
	16	56104229	1	Grommet	K7	50		1	Nut, Hex Nyl Loc Thin M6 Ss
	17#	51526A	1	Hosebarb 3/8 X 90 Deg	K3,K7	51		2	Scr, Pan Phil M4x10 Ss
	18	56104234	1	Actuator Brkt	K7	52		1	Washer, Flat XI Ss
K5	19		1	Actuator Assembly (M3)	K7	53#		6	Scr,Pan Phil M5x16 Ss
	20	56104308	2	Pivot Block	K2	54#		1	Hose, Solution
K5	21		1	Spacer Actuator		55#	L08603845	2	Clamp Cable
K4	22		1	Rubber Solution Cap	K2	56#	33003496	1	Clamp Hose Parana 13/20
	23	56104390	1	Insert-Brass M8					
	24	56104391	1	Adjustment Pad	K1	56104349		1	Kit-Solution Drain
	25	56104408	1	Chemical Bottle Assembly	K2	56104350		1	Kit-Solution Hose
	26	56104409	1	Prop Rod	K3	56104351		1	Kit-Solution Filter
K4	27		1	Clip, Panel	K4	56104354		1	Kit-Solution Cap
K7	28		1	Bushing	K5	56104356		1	Kit-Actuator
	29	56314942	1	Hose, Chem Resistant	K6	56104357		1	Kit-Tip Pad
	30	56314991	1	Hose, Chem Resistant 14"	K7	56104358		1	Kit-Solution Hardware

= Revised or new since last update

SQUEEGEE SYSTEM

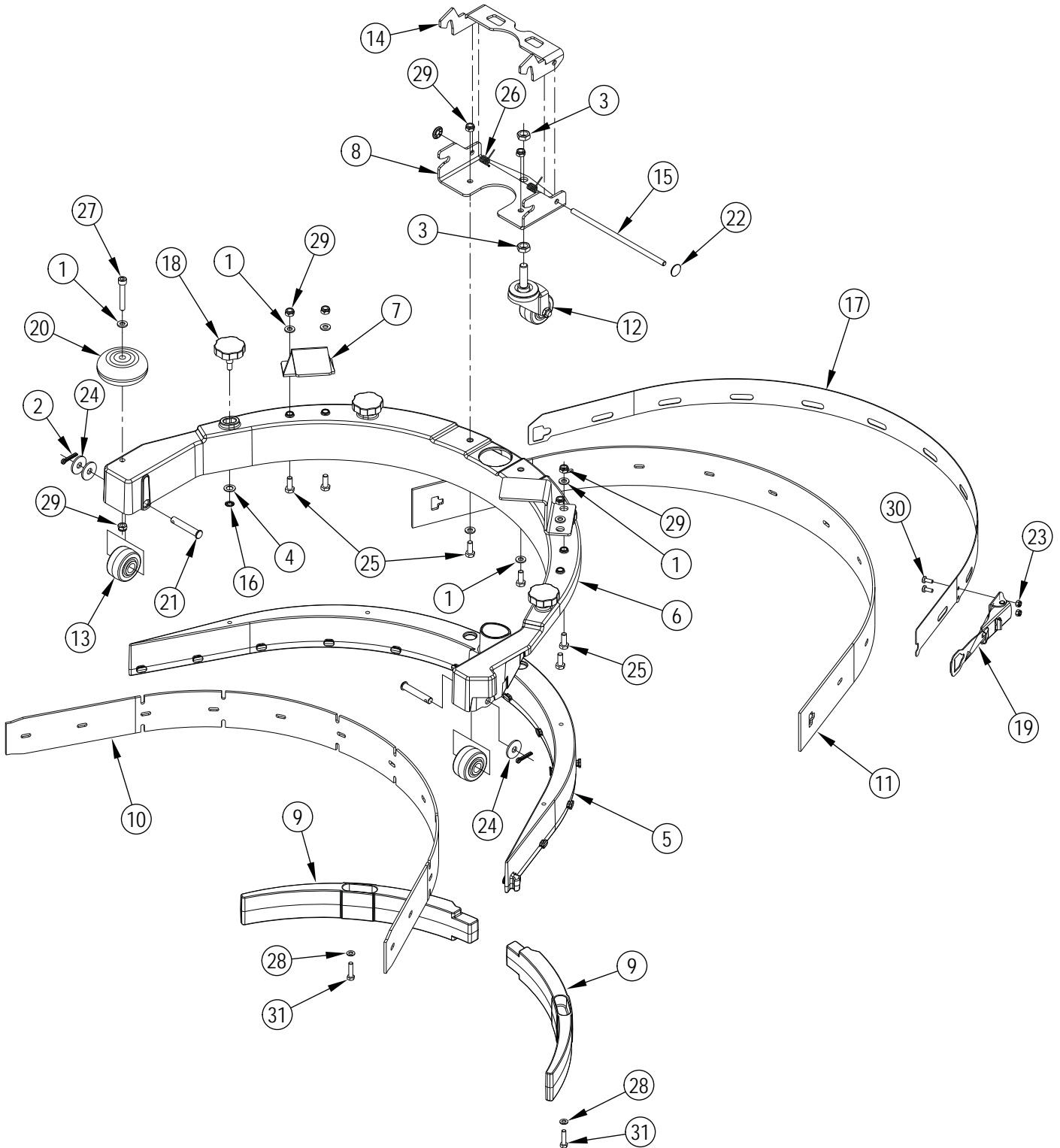

SQUEEGEE SYSTEM

Kit	Item	Ref. No.	Qty	Description
K3,K4,K6	1		7	Washer, Flat 6,4X12,5 S.S.
K4,K6	2		2	Pin-Cotter 1/8 X .75
K4,K6	3		2	Nut-Hex Jam Ss 3/8-16
K4,K5	4		4	Wsh-Flt .328 X .563 X .031
K4	5		1	Squeegee Casting NOTE 2
K4	6		1	Squeegee Cover
K4	7		2	Squeegee Lift Bracket
K4,K8	8		1	Squeegee Bracket
K4	9		2	Squeegee Plate
K1,K4	10		1	Blade-Squeegee Pu Front NOTE 1
K2	*		1	Blade-Squeegee Red Gum Front NOTE 1
K1,K4	11		1	Blade-Squeegee Pu Rear NOTE 1
K2	*		1	Blade-Squeegee Red Gum Rear NOTE 1
K4,K6	12		1	Caster Wheel
K4,K6	13		2	Roller Wheel
K4,K8	14		1	Squeegee Mount Brkt
K4,K8	15		1	Pivot Pin
K4,K5	16		4	Retaining Ring
K4,K7	17		1	Strap-Squeegee Rear
K4,K5	18		4	Knob Assembly
K4,K7	19		1	Latch-T Tab Assy
K4,K6	20		1	Roller Wheel
K4,K6	21		2	Pin-Clevis .312 X 1.84
K4,K8	22		2	Pin Cover-6mm
K4,K7	23		2	Nut, Hex Nyl Loc Thin M4 Ss
K4,K6	24		3	Washer 8x24x2 Uni 6593 Ss
K3,K4	25		6	Screw, Hex Thd To Hd M6x16 Ss
K4,K8	26		2	Spring Acc. Lid Lh
K4,K6	27		1	Viti Tcei/Scr, Soc Hd
K3,K4	28		2	Washer, Flat 5.3X10X1 Ss
K3,K4,K6	29		7	Nut, Hex Nyl Loc Thin M6 Ss
K4,K7	30		2	Scr, Pan Phil M4x10 Ss
K3,K4	31		2	Screw, Hex Thd To Hd M5x20 Ss
	K1	56104325	1	Kit-Squeegee Blade Pu
	K2	56104326	1	Kit-Squeegee Blade Red Gum
	K3	56104327	1	Kit-Squeegee Hardware
	K4	56104378	1	Kit-Squeegee Assy
	K5	56104382	1	Kit-Squeegee Knobs
	K6	56104385	1	Kit-Squeegee Wheels
	K7	56104386	1	Kit-Squeegee Strap
	K8	56104387	1	Kit-Squeegee Mount Brkt

* = Optional, Not Included

NOTE 1: All squeegee blade kits include both front and rear squeegee blades.

NOTE 2: The squeegee casting is not available for sale separately. If you need to replace it please order the Kit-Squeegee Assy 56104378.

LADDER DIAGRAM

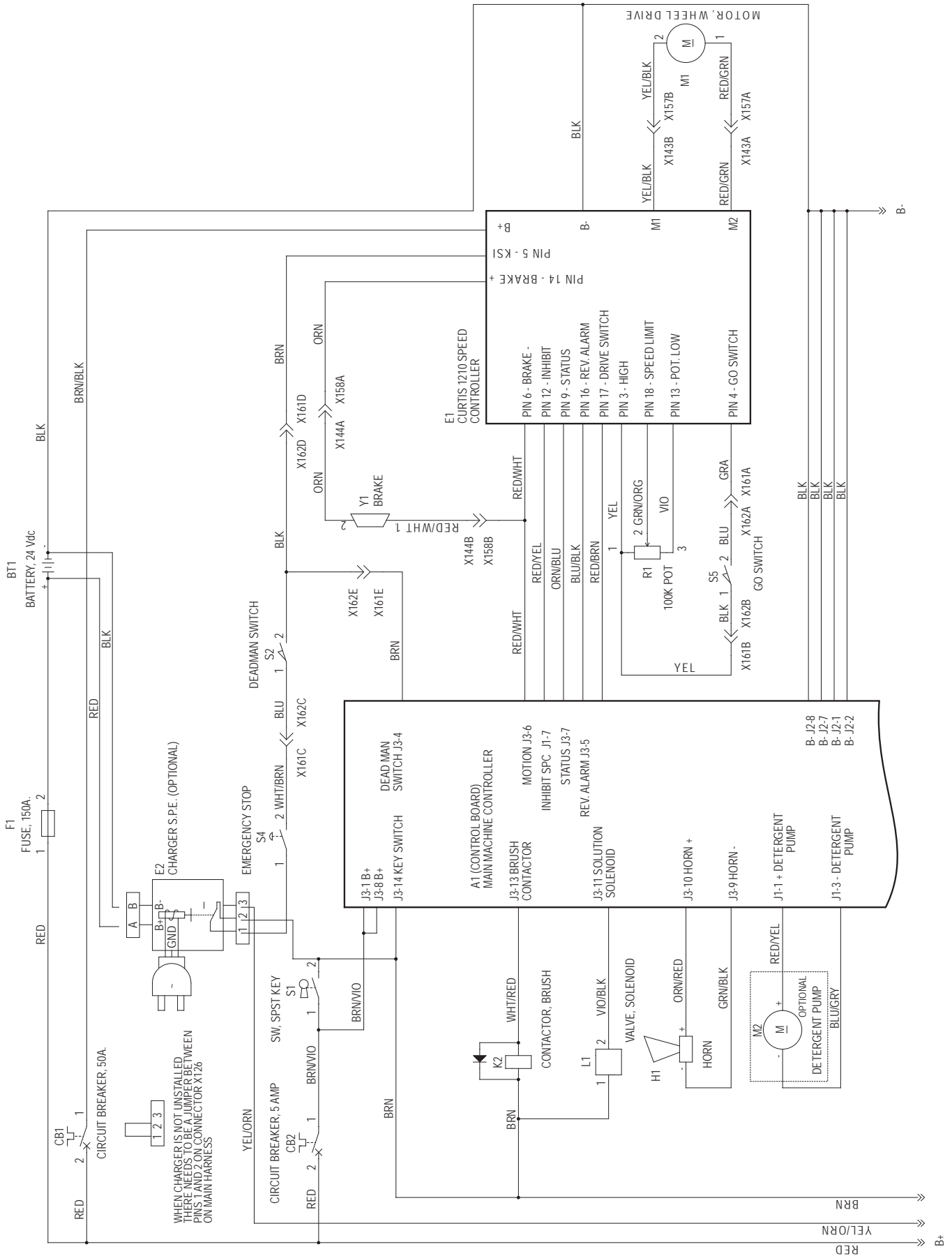

LADDER DIAGRAM

Item	Ref. No.	Qty	Description
A1	NA		Control Board
BT1	NA		Battery
CB1#	56104423	1	Circuit Breaker 50A (Drive Wheel)
CB2#	56315255	1	Circuit Breaker 5 Amp (Control Circuit)
CB3#	56413822	1	Circuit Breaker 20 Amp (Vacuum Motor)
CB4#	56509623	1	Circuit Breaker-25 Amp (Brush Motor)
E1	56104243	1	Speed Controller
E2	56112544	1	Battery Charger 24V 25A
F1	56412089	1	Fuse 150 Amp
H1	909 6126 000	1	Buzzer 5-32v
K1	56104176	1	Solid State Relay
K2	56601183	1	Contactora 24v 100 Amp
L1	56601064	1	Solenoid Valve Assembly
M1#		1	Drive Wheel Motor
M2	56315241	1	Pump Chemical
M3#	56104288	1	Actuator Assembly (Motor Brush Lift Actuator)
M4	909 7556 000	1	Motor Vacuum 3st 24v 420w
M5	56104071	1	Disc Brush Motor (20D)
M5	56390072	1	Motor 24vdc (REV)
R1	56396197	1	Potentiometer 100k (Speed Adjustment)
S1	146 2888 000	1	Switch Key with Cap
S2	NA	1	Switch-Sealed (part of Switch Harness 56104406)
S4	56104247	1	Disconnect-Emergency
S5	NA	1	Switch-Sealed (part of Switch Harness 56104406)
Y1#	NA		Electrical Brake (part of Drive Wheel Motor M1)

= Revised or new since last update

LADDER DIAGRAM

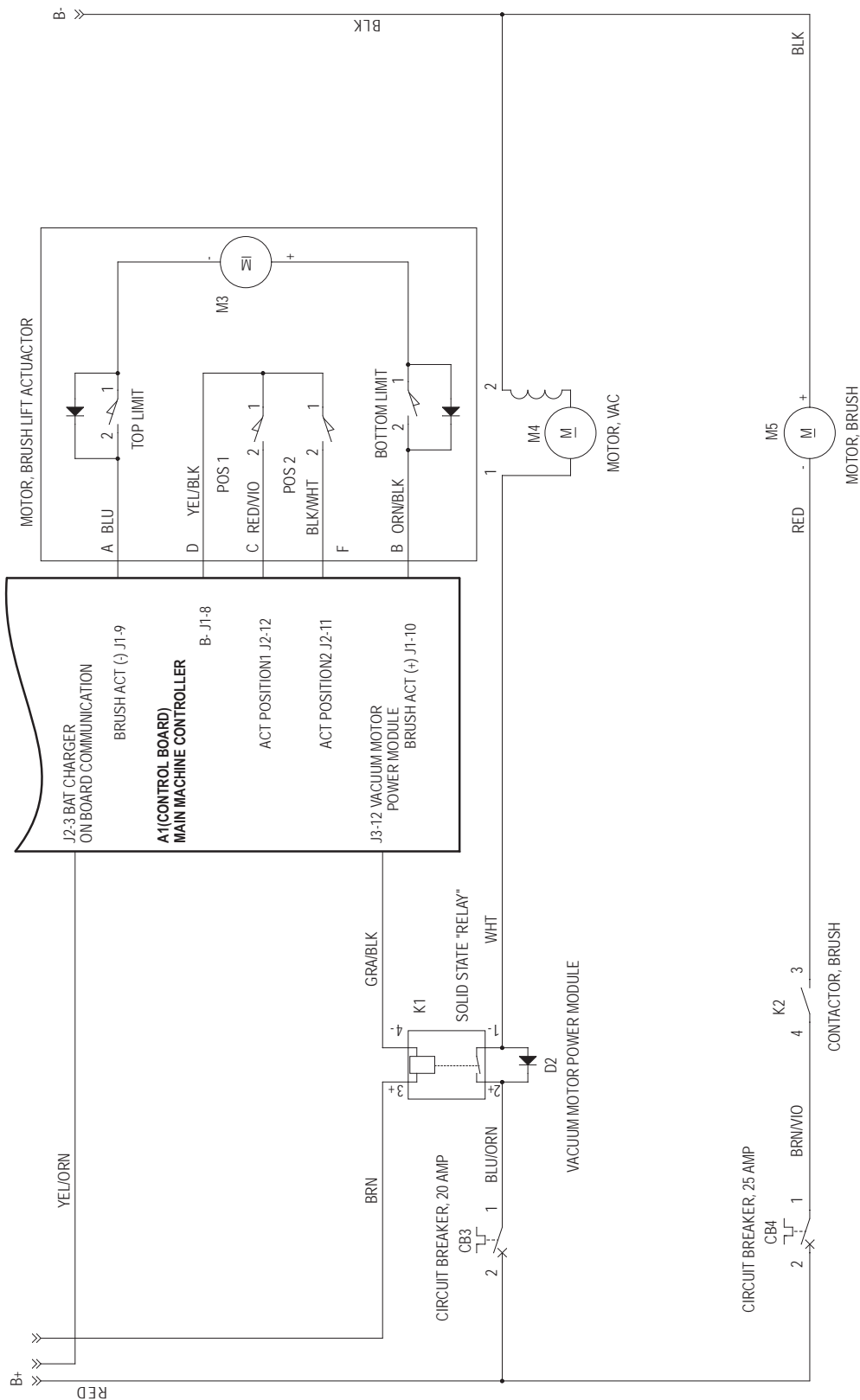

LADDER DIAGRAM

Item	Ref. No.	Qty	Description
A1	NA		Control Board
BT1	NA		Battery
CB1#	56104423	1	Circuit Breaker 50A (Drive Wheel)
CB2#	56315255	1	Circuit Breaker 5 Amp (Control Circuit)
CB3#	56413822	1	Circuit Breaker 20 Amp (Vacuum Motor)
CB4#	56509623	1	Circuit Breaker-25 Amp (Brush Motor)
E1	56104243	1	Speed Controller
E2	56112544	1	Battery Charger 24V 25A
F1	56412089	1	Fuse 150 Amp
H1	909 6126 000	1	Buzzer 5-32v
K1	56104176	1	Solid State Relay
K2	56601183	1	Contactora 24v 100 Amp
L1	56601064	1	Solenoid Valve Assembly
M1#		1	Drive Wheel Motor
M2	56315241	1	Pump Chemical
M3#	56104288	1	Actuator Assembly (Motor Brush Lift Actuator)
M4	909 7556 000	1	Motor Vacuum 3st 24v 420w
M5	56104071	1	Disc Brush Motor (20D)
M5	56390072	1	Motor 24vdc (REV)
R1	56396197	1	Potentiometer 100k (Speed Adjustment)
S1	146 2888 000	1	Switch Key with Cap
S2	NA	1	Switch-Sealed (part of Switch Harness 56104406)
S4	56104247	1	Disconnect-Emergency
S5	NA	1	Switch-Sealed (part of Switch Harness 56104406)
Y1#	NA		Electrical Brake (part of Drive Wheel Motor M1)

= Revised or new since last update

OPTIONAL KITS AND ACCESSORIES

Item	Ref. No.	Qty	Description
Kits			
*	56104403	1	Kit-On Board Charger-Eu
*	56104374	1	Kit-Shelf Charger Us
*	56104371	1	Kit-Control Board
*	56104372	1	Kit-Interface Panel
Squeegee Blade Kits (See Squeegee Blade Selector Guide)			
	56104325	1	Kit-Squeegee Blade PU NOTE 1
*	56104326	1	Kit-Squeegee Blade Red Gum NOTE 1
Accessories			
*	56397453	1	Indicator Battery Level
*	56409441	1	Programmer 1311np User
*	56409823	1	Programmer Cable
*	56104190	1	Ecoflex Bottle Assy
*	56104192	1	Kit-Chemical Injection Eu
*	56044628	1	Literature Pack
20" Disk Scrub Brushes (See Brush Selector Guide)			
*	56505790	1	Pad Holder-20 3 Lug
*	56505791	1	Disc Brush-20 Magnagrit 3 Lug
*	56505792	1	Disc Brush-20 Dyna Grit 3 Lug
*	56505793	1	Disc Brush-20 Aglite 3 Lug
*	56505794	1	Disc Brush-20 Prolene 3 Lug
*	56505795	1	Disc Brush-20 Prolite 3 Lug
*	56505796	1	Disc Brush-20 Union Mix 3 Lug
*	56505797	1	Disc Brush-20 Midgrit 3 Lug
*	56505798	1	Disc Brush-20 Midlite 3 Lug
*	976170	1	Pads Cs 20 Black Thin (Qty 5)
*	976070	1	Pads Cs 20 Brown 51 (Qty 5)
*	976069	1	Pads Cs 20 Blue 51 (Qty 5)
REV Pads (See Pad Selector Guide)			
*	56390045	1	Velcro 2 Sided 20
*	56390046	1	Pad Maroon Spp20 (Qty 5)
*	56390079	1	Pad Micro Fiber
*	976068	1	Pad 20-In Red 5100 (Qty 5)
*	976067	1	Pads Cs 20 White 51 (Qty 5)

* = Optional, Not Included

NOTE 1: All squeegee blade kits include both front and rear squeegee blades.

RECOMMENDED SPARE PARTS**CLASS**

W = Normal Wear
 O = Ordinary Maintenance
 E = Extra-Ordinary Maintenance

CLASS PART NO. DESCRIPTION**CHASSIS SYSTEM**

E 56104091 Mounting Tab
 E 56104094 Bar Linkage
 E 56104105 Battery Tray
 E 56104130 Steering Shaft
 E 56104135 Link Bar
 E 56104148 Steering Shaft Weldt
 E 56104151 Spindle Mount Weldment
 E 56104157 Collar
 E 56104170 Chassis Weldment
 O 56104239 Harness-Drive Motor
 O 56104269 Sprocket-11 Tooth
 O 56104407 Bearing-Flange
 E 56314032 Block, Bearing
 E 56112544 Battery Charger 24v 25a
 E 56104328 Kit-Universal Joint
 O 56104331 Kit-Rear Wheel
 E 56104332 Kit-Bearing Block
 E 56104333 Kit-Chassis Hardware
 E 56104336 Kit-Drive Wheel Motor
 O 56104338 Kit-Wheel And Bearing
 O 56104339 Kit-Sprocket And Chain
 E 56104340 Kit-Drive Wheel Hardware
 E 56104384 Kit-Front Wheel Bearings

CONTROL SYSTEM

E 56104053 Control Panel
 E 56104196 Shaft Steering
 E 56104265 Shaft Hex
 E 56104410 Bracket-Prop Rod
 E 56601060 Steering Wheel
 E 56104058 Drive Wheel Frame Weldt
 E 56104077 Spindle Weldt
 E 56104115 Steering Plate
 W 56104270 Chain-Roller
 E 56104328 Kit-Universal Joint
 E 56104352 Kit-Draw Latch
 E 56104365 Kit-Control Hardware

ELECTRICAL SYSTEM

E# 56104423 Circuit Breaker 50 Amp
 E 56104083 Harness-Main
 E 56104176 Solid State Relay
 E 56104193 Electrical Panel
 E 56104243 Speed Controller
 E 56104247 Disconnect-Emergency
 E 56104281 Cable-Power
 E 56112354 Handle
 E 56315255 Circuit Breaker, 5 Amp
 E 56396197 Potentiometer, 100k
 E 56409485 Cable,Battery
 E 56412089 Fuse, 150 Amp
 E 56413822 Circuit Breaker, 20 Amp
 E 56469858 Electrical Mount
 E 56509623 Circuit Breaker-25 Amp
 E 56601172 Connector Assy
 E 56601183 Contactor 24v, 100 Amp
 E 146 2888 000 Switch, Key With Water Proof Cup
 E L08812063 Terminal Clamp Batt
 E L08812064 Terminal Clamp Batt
 E 50962A Knob, Speed Control
 E 2-00-05171 Boot, Protective (Red)
 E 2-00-05173 Battery Insulator
 E 56104282 Cable-Power Red
 E 56104283 Cable-Power Black
 E 56372673 Boot-Battery Post
 E 56478246 Tie, Cable
 E 40172A Cable,Battery
 E 56104341 Kit-Electrical Hardware
 E 56104371 Kit-Control Board
 E 56104372 Kit-Interface Panel

CLASS PART NO. DESCRIPTION**PLATFORM ASSEMBLY**

E 56104052 Platform-Upper
 E 56104185 Pedal-Safety
 E 56104186 Foot Pedal
 E 56104187 Platform-Bottom
 E 56104277 Compression Spring
 O 56104406 Switch Harness
 E 56158690 Grommet
 E 56331006 Grommet
 E 56104417 Kit-Platform Assembly

RECOVERY SYSTEM

E 56104051 Recovery Tank
 E 56104158 Back Panel
 O 56104164 Gasket-Recovery Tank
 O 56104258 Vac Hose Assy
 O 56104285 Drain Hose
 E 56104306 Jumper Harness
 E 56104320 Splash Guard
 E# 145 0543 000 Clamp, Hose 14/32-52
 E 909 6051 000 Cover, Vac
 O 909 6672 000 Filter
 E 56104352 Kit-Draw Latch
 E 56104359 Kit-Float Cage
 E 56104360 Kit-Debris Cage
 E 56104362 Kit-Hose Clamp
 E 56104363 Kit-Vacuum Motor
 E 56104364 Kit-Recovery Hardware
 E 56104383 Kit-Vacuum Motor Insulation

SCRUB SYSTEM-20D

E 56104071 Disc Brush Motor
 E 56104095 Shaft Disc Brush Motor
 E 56104117 Deck Lift Plate Weldment
 E 56104120 Lower Deck Plate
 E 56104121 Brush Housing
 E 56104126 Squeegee Link Weldment
 E 56104137 Spacer Motor
 E 56104169 Solenoid Valve Assy
 E 56104240 Skirt Brush
 E 56104241 Double Scrub Brkt
 E 56314983 Tee Assembly
 E 56386183 Barbed Elbow 90
 E 56397209 Hose, Pvc, Clear .50 X 4.00
 E 56397217 Hose, Pvc Clear
 E 56601733 Brush Plate Assy Rt
 E 56366455 Plate, Stop
 E 56109653 Spring Retainer
 E 56112521 Gimbal-Collar Assembly
 E 56601056 Spring, Brush Holder
 E 56601118 Brush Plate
 O 909 5483 000 Hose Holder
 E 56104297 Motovario Gearbox 15/1
 E 56104298 Motor
 E 56104300 Brush Housing Assembly
 E 56601588 Cover And Screws
 E 56601508 Plastic Cover
 O 56601534 Carbon Brushes (2)
 E 56104344 Kit-Squeegee Pivot
 E 56104346 Kit-Disc Deck Hardware
 E 56104347 Kit-Disc Deck Assy 20

SCRUB SYSTEM-REV

E 56104138 Rev Lift Plate Weldment
 E 56104169 Solenoid Valve Assy
 E 56104201 Plate Pivot
 E 56104202 Housing Rev
 E 56104203 Squeegee Link Weldment
 E 56104241 Double Scrub Brkt
 E 56104244 Plate Motor
 E 56114200 Connector-Adaptor
 E 56390011 Shield Splash
 E 56390038 Gasket Driver

CLASS PART NO. DESCRIPTION**SCRUB SYSTEM-REV CONTINUED**

E 56390044 Pad Driver Assy
 E 56381532 Stud Stabilizer Short
 E 56390002 Weight Counter
 E 56390021 Eccentric
 E 56390027 Driver Motor
 E 56390072 Motor 24vdc
 O 56412287 Carbon Brush Set Of 2 (For 56390072)
 E 50736A Bearing
 E 61775A Retainer, Bearing
 E 56104366 Kit-Rev Deck Assy
 E 56104367 Kit-Rev Deck Hardware
 E 56104368 Kit-Rev Squeegee Pivot
 E 56104369 Kit-Isolator
 E 56104370 Kit-Rev Solution Hose

SOLUTION SYSTEM

E 56104050 Solution Tank
 E 56104165 Filter Bracket
 E 56104194 Support Brkt
 E 56104206 Hinge Pin
 E 56104207 Hinge Weldment
 E 56104208 Hinge Bracket
 E 56104249 Bearing Flange
 E 56104229 Grommet
 E# 51526A Hosebarb 3/8 X 90 Deg
 E 56104234 Actuator Brkt
 E 56104308 Pivot Block
 E 56104390 Insert-Brass M8
 E 56104391 Adjustment Pad
 E 56104409 Prop Rod
 E 56393382 Hose-Pvc Clear
 E 56477613 Tie, Cable
 E 56601599 Cap - Raw With Tether
 E 909 6126 000 Buzzer 5-32v
 E 56104189 Insert-Dry Break
 E 56104408 Chemical Bottle Assembly
 E 56314942 Hose, Chem Resistant
 E 56314991 Hose, Chem Resistant 14"
 E 56315241 Pump, Chemical
 E 56315270 Charger Cord, Us
 E 56315517 Cap, Raw
 E 56315523 Cap, Dry Break, 1/8 Barb, 90
 E 909 5149 000 Cable Support
 E 56104349 Kit-Solution Drain
 E 56104350 Kit-Solution Hose
 E 56104351 Kit-Solution Filter
 E 56104354 Kit-Solution Cap
 E 56104356 Kit-Actuator
 E 56104357 Kit-Tip Pad
 E 56104358 Kit-Solution Hardware
 E 56112355 Kit- Refilling Hose

SQUEEGEE SYSTEM

W 56104325 Kit-Squeegee Blade Pu
 W 56104326 Kit-Squeegee Blade Red Gum
 E 56104327 Kit-Squeegee Hardware
 E 56104378 Kit-Squeegee Assy
 E 56104382 Kit-Squeegee Knobs
 W 56104385 Kit-Squeegee Wheels
 E 56104386 Kit-Squeegee Strap
 E 56104387 Kit-Squeegee Mount Brkt

DECAL SYSTEM - SC1500

E 56104334 Kit-Decal Sc1500

DECAL SYSTEM - SC1500 REV

E 56104348 Kit-Decal Sc1500 Rev

ACCESSORY / OPTIONS

E 56104374 Kit-Shelf Charger Us

= Revised or new since last update

BRUSH SELECTOR GUIDE

We provide brushes and pad holders that will give you the best possible performance between machine and floor. Following are descriptions of the materials and their applications.

- Soft Nylon:** Bristles are made from light-duty polypropylene for general scrubbing when you do not want to scratch or remove finish from the floor. Recommended for use in place of red pads.
- Poly:** Polypropylene material for medium-duty scrubbing on concrete, terrazzo and vinyl floor tile. Recommended for use in place of green or blue pads.
- Lite Grit:** For light scrubbing when used wet; buffing or polishing when used dry on urethane coated, sealed concrete or other resilient hard surface floors. Recommended for use in place of red or white pads.
- Medium Grit:** For general purpose scrubbing of sealed or unsealed concrete, stone, terrazzo, quarry tile and other resilient hard floor surfaces. Recommended for use in place of green or blue pads.
- Heavy Grit:** For aggressive, heavy-duty scrubbing or stripping of floors. Recommended for use in place of brown pads.

20" Disk Scrub Brushes

- 56505790 - Pad Holder
- 56505791 - Magnagrit
- 56505792 - Dyna Grit
- 56505793 - Aglite
- 56505794 - Prolene
- 56505795 - Prolite
- 56505796 - Union Mix
- 56505797 - Midgrit
- 56505798 - Midlite
- 976170 - Pads Cs 20 Black Thin (Qty 5)
- 976070 - Pads Cs 20 Brown 51 (Qty 5)
- 976069 - Pads Cs 20 Blue 51 (Qty 5)

DISC BRUSH APPLICATION GUIDE (SUGGESTION ONLY)

Application	Heavy Grit	Medium Grit	Lite Grit	Poly	Soft Nylon
Stripping:					
Concrete	X				
Terrazzo	X				
Ceramic/Quarry tile	X				
Vinyl tile	X				
General Scrubbing:					
Concrete	X	X	X	X	
Terrazzo		X	X	X	
Ceramic/Quarry tile		X	X	X	
Marble			X	X	X
Vinyl tile		X	X	X	
Raised-rubber tile			X	X	X

PAD SELECTOR GUIDE

We provide pads that will give you the best possible performance between machine and floor. Following are descriptions of the materials and their applications.

- White: For very light scrubbing on high gloss floor finishes where a red pad may be too aggressive.
- Red: Most popular daily cleaning and scrubbing pad for use on a wide varieties of floors.
- Blue: For heavy duty scrubbing prior to recoating. Removes dirt, spills and scuffs, leaving a clean surface ready for recoating.
- Black: For conventional stripping with chemicals.
- 3M Hi Pro: For conventional stripping with chemicals. Unique open web construction allows stripping solution to flow through the pad to rinse out dirt and reduce loading for increased pad-to-floor contact and more efficient stripping.
- Maroon: Prepares wood, vinyl tile, sheet vinyl, marble, terrazzo and concrete floors for refinishing.

REV Deck Pads

56390045 - Velcro 2 Sided

56390046 - Pad Maroon Spp20 (Qty 5)

56390079 - Pad Micro Fiber

976068 - Pad 20-In Red 5100 (Qty 5)

976067 - Pads Cs 20 White 51 (Qty 5)

SQUEEGEE BLADE SELECTOR GUIDE

Red Gum Rubber: Provides longest life on finished or unfinished concrete floors.

Polyurethane: Oil resistance provides superior life in applications with oily floors.

SQUEEGEE BLADE APPLICATION GUIDE(SUGGESTION ONLY)

Performance Traits	Red Gum Rubber (Natural Rubber)	Polyurethane/ Pentathane
Resilience		X
Tear Strength		X
Abrasion Resistance	X	X
Wear Resistance	X	X
Low Temp Flexibility	X	
High Temp Flexibility		X
Ozone Resistance		
Chemical Resistance		X
Applications		
Oil Resistant Applications		X
General Purpose	X	X
Hot Water Applications	X	X
Chemical Applications		X
Color	Red	Translucent



Nilfisk-Advance Equipamentos de Limpeza Ltda.
Av. Dep. Emílio Carlos, 2.499 - Bairro do Limão - 02721-200
São Paulo - SP - Brasil
www.nilfisk-advance.ind.br
www.plataforma.ind.br
Tel.: (11) 3959-0300
Fax: (11) 3959-0306
©2013 Nilfisk-Advance, Inc.



14600 21st Avenue North
Plymouth, MN 55447-3408
www.advance-us.com
Phone: 800-989-2235
Fax: 800-989-6566
©2013 Nilfisk-Advance, Inc.